



ATMOSPHERIC SEAL
18 CPM



GAS FLUSH
14 CPM



HERMETIC SHRINK
18 CPM



GTOs

Automatic, medium-capacity, high-speed, in-line tray sealing system designed to cut labour costs.

It combines high throughput with rapid tool-changing and space-saving compact design.

Optional 'free-flow' gas flush Modified Atmosphere Packaging (MAP) available for extended shelf life.

Capable of up to 36 Atmospheric packs per minute with a 2 impression tool, the GTOs system is packed with user-friendly benefits including our unique Promotion modular conveyor system.

Designed to accept randomly spaced trays from any conveyor and can be fully integrated with other line equipment.

Packaging Materials

Trays

- C-PET
- A-PET
- R-PET
- Polypropylene
- PVC / Styrene
- Board / Paper
- Smooth Wall Foil

Lidding

- Co-extruded and Laminated Polyester Films
- Foil
- Board
- Paper

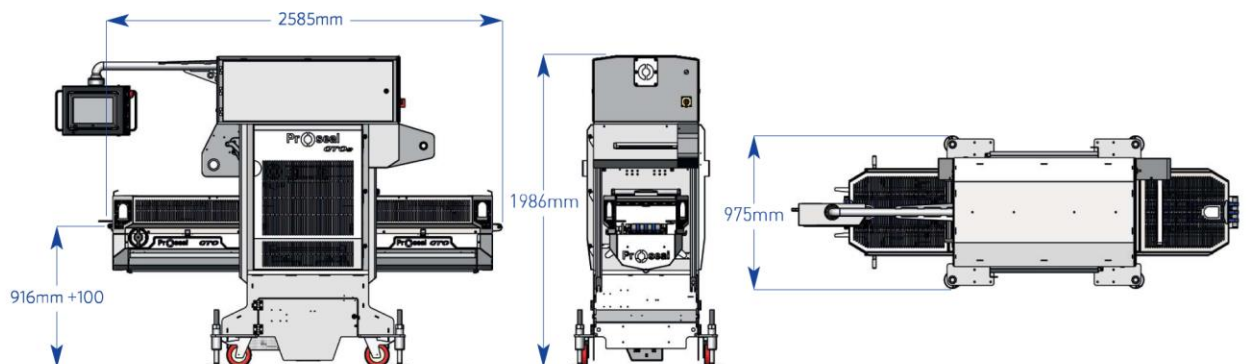

Standard design features and benefits

- Two minute tool changeover
- Low maintenance polymer bearings
- Simple and accurate film-feed system with easy film route
- Maintenance friendly robust construction
- Accurate temperature and seal pressure control
- High accuracy tool alignment system provides a constantly accurate sealing and/or film-cutting relationship with the tray flange profile
- Simple design and operation
- Film snap detection
- 'Auto Tool' Touch of a button tool change system, automatically locates and connects tooling to machine functions including all MAP options
- All around seal and contoured film-cut with skeletal film rewind
- Automatic seal operation with accurate seal dwell time
- Self-centring tray guides
- Automatic film roll clamping
- Food industry approved hygienic construction and wash-down protection
- Full Category 3 guarding
- User friendly, menu-driven control panel with step-by-step prompts, error and status displays, and useful batch pack counter
- Recipe handling of machine settings
- Self diagnostic system
- Pendant mounted colour touch screen HMI control for full double-sided operation
- Recipe driven auto machine set-up for tool change
- On-screen data capture and trends with wireless connection option
- Pot crush avoidance system
- Active film tension
- Integration of peripheral equipment, such as: infeed and outfeed conveyors, checkweighers, metal detectors and printers
- QR Conveyors** with quick release belts for easy hygiene and maintenance
- Eseal®** - high-performance, high-precision, high-force, energy-efficient, electric seal system that boasts a massive increase in seal force
- Promotion** - a high accuracy continuous motion tray infeed system, which increases production speed whilst reducing machine duty

Options available

- Free flow gas flush MAP (Modified Atmosphere Packaging)
- High Oxygen (O²) gas flush
- Close Cut - Method of maximising throughput and reducing film waste
- Inboard Cut (IC) Option to provide 'form, fill and seal' tray presentation
- Film coding and printing
- Foil crimping
- Active conveyors to allow the machine to be used as a straight through conveyor when packs don't require sealing
- Back-to-back machine configurations
- Optional integration of peripheral equipment, such as: denesters, fillers, multi-head weighers, laser coders, labellers
- eWON** - a machine connection system to deliver real time data and error condition support, remote setup, and software upgrades, using a customer's existing IT network
- I-film** - intelligent film reel monitoring system which actively adjusts film tension based on reel diameter to increase print quality and film reel efficiency, reduce component duty, and provides a film end warning system
- Protect** - a contactless machine login and audit trail system
- Sale, Lease Purchase and Rental options available

GTOS Specifications

Height	1986mm
Standard Length	2585mm
Width	975mm
Weight	1000kg
Electrical Supply	400V 3 phase + neutral (fused at 16A)
Transformer Variations	208V 3 phase (fused at 30A) 480V 3 phase (fused at 20A) 600V 3 phase (fused at 15A)

GTOS Sealing capacity

No. of trays	Length	Width	Depth	Diameter
One	300mm	439mm	105mm	270mm
Two	300mm	207mm	105mm	207mm
Three	300mm	104mm	105mm	104mm
Four	300mm	71mm	105mm	71mm

Metric

Imperial

Pressure	Flow	Pressure	Flow
6 Bar	50L/Min	87psi	1.7CFM

Transformers are available to accommodate the electrical supplies in different countries



PRODUCE | A-PET



SNACK FOOD | A-PET



READY MEALS | SMOOTH WALL FOIL



READY MEALS | C-PET



PUDDING | C-PET

for more information UK +44 (0) 1625 856 600 America +1 804 447 9038 Australia +61 (0) 3 9397 0955

www.proseal.com

Panmatex Trading Sdn Bhd +603 8075 8008 enquiry@pmtgroup.com.my

www.pmtgroup.com.my

